

CONNECTION GUIDE



HD TERMINAL
MULTI-ROOM HD PVR
MULTI-ROOM HD PVR 8X

TABLE OF CONTENTS

Welcome	3
Activation	4
Your Terminal	5
Connection	8
Your Remote Control	9
Programming Your Remote Control	10
Equipment Settings	12
Frequently Asked Questions	13
Customer Service and Technical Support	15
Security	16
Notes	18

For more information, visit us at videotron.com/terminal-support

CONGRATULATIONS ON YOUR PURCHASE OF THIS HD TERMINAL OR MULTI -ROOM HD PVR, YOUR GATEWAY TO THE ILLICO TV NEW GENERATION EXPERIENCE.

With illico TV new generation:

- Enjoy a new, customized TV experience that's faster, more powerful and easier to use
- Get a faster, user-friendly browsing tool
- Manage your recordings easily with the Multi-Room HD PVR
- Gain access to a personalized interactive 15-day Program Guide
- Use handy apps like the Miniguide and a variety of widgets (i.e. weather forecasts, lottery results, illico news, etc.)
- Fully immerse yourself in the HD experience thanks to exceptional image quality and menus adapted to HD TVs
- Watch your recordings on any TV in your home, thanks to the Multi-Room PVR

Entertainment that gives you:

- Exclusive access to illico On-Demand, which offers thousands of movies and shows, many of which you can watch for free
- Access to Club illico. Available with your monthly subscription, Club illico gives you access to a vast catalogue of French on-demand movies, series, kids' shows and documentaries

A multi-screen experience means:

- You can watch your favourite movies and shows wherever you want, on the screen of your choice, with channel 900, illico.tv or one of our illico apps for mobiles and tablets.

ACTIVATION

If you received your Terminal via Canada Post, please follow these steps:

1. Connect your Terminal by referring to the **Connect Your Terminal** section.
2. Once your Terminal is plugged in, dial the number below to activate it.
Toll-free: 1-877-226-6385. Monday to Friday: 7:30 a.m. to 10 p.m.
| Saturday and Sunday: 8 a.m. to 8 p.m.
3. Follow steps 3 to 5 below.

If you bought your HD Terminal or Multi-Room HD PVR from one of our authorized dealers (rather than in a Videotron store), please follow these steps:

1. Connect your Terminal by referring to the **Connect Your Terminal** section.
2. Turn on the Terminal. Activation should start automatically and may take up to 10 minutes.
- If activation fails, dial 514-380-7834 or 1-866-380-2134.
Monday to Friday: 7:30 a.m. to 10 p.m. | Saturday and Sunday: 8 a.m. to 8 p.m.
3. Complete the Quick-Start Wizard that automatically appears when your Terminal is turned on for the first time.
The Quick-Start Wizard allows you to:
 - i. Select your preferred language.
 - ii. Activate an Administrator PIN for managing certain functions on the Terminal and ordering on-demand content. Administrator PIN: _____
 - iii. Activate and configure Parental Controls.
4. Create an Order PIN to access content that is permitted by Parental Controls.
Order PIN: _____
5. Follow the instructions on page 10 to program the remote to your TV.



IMPORTANT: If the error message "WIZ 502" appears on the screen, you should immediately contact Videotron Technical Support (p. 15), as this indicates that some applications will not work.

For more information, visit us at videotron.com/terminal-support

SAMSUNG 6340 HD TERMINAL



SAMSUNG 8340 HD PVR



BACK OF THE TERMINAL

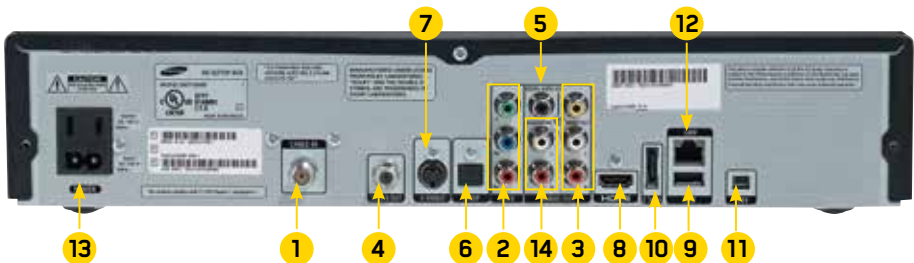

- | | | | |
|---|------------------------------|----|---------------------------------------|
| 1 | Coaxial audio/video input | 8 | HDMI audio/video output |
| 2 | Component video output | 9 | USB port (currently unavailable) |
| 3 | RCA audio/video output | 10 | eSATA port (only available on HD PVR) |
| 4 | Coaxial audio/video output | 11 | Firewire port (currently unavailable) |
| 5 | Digital coaxial audio output | 12 | Ethernet port (currently unavailable) |
| 6 | Optical audio output | 13 | Power supply |
| 7 | S-Video output | 14 | RCA audio output |

NOTE: Pictures for reference purposes only

For more information, visit us at videotron.com/terminal-support

CISCO 4642 HD TERMINAL



CISCO 8642 HD PVR



BACK OF THE TERMINAL

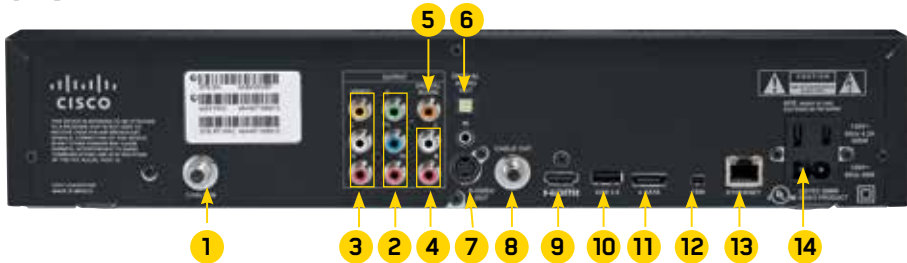

- | | | | |
|---|---------------------------|----|---|
| 1 | Coaxial audio/video input | 8 | Coaxial audio/video output |
| 2 | Component video output | 9 | HDMI audio/video output |
| 3 | RCA audio/video output | 10 | USB port (currently unavailable) |
| 4 | RCA audio output | 11 | eSATA port (only available on the HD PVR) |
| 5 | Digital coax audio output | 12 | Firewire port (currently unavailable) |
| 6 | Optical audio output | 13 | Ethernet port (currently unavailable) |
| 7 | S-Video output | 14 | Power supply |

NOTE: Pictures for reference purposes only

For more information, visit us at videotron.com/terminal-support

CISCO EXPLORER 9887 HD PVR



BACK OF THE TERMINAL

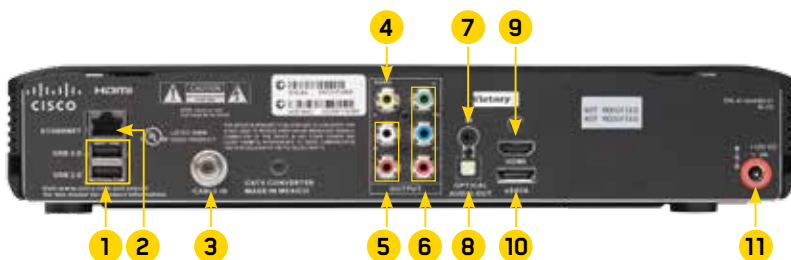

- | | | | |
|---|---------------------------------------|----|---------------------------------------|
| 1 | USB ports (currently unavailable) | 7 | Infrared port (currently unavailable) |
| 2 | Ethernet port (currently unavailable) | 8 | HDMI audio/video output |
| 3 | Coaxial audio/video input | 9 | HDMI audio/video output |
| 4 | RCA video output | 10 | eSATA port (currently unavailable) |
| 5 | Digital coaxial audio output | 11 | Power supply |
| 6 | Optical audio output | | |

For more information, visit us at videotron.com/terminal-support

CONNECTION

CONNECTING YOUR HD TERMINAL OR MULTI -ROOM HD PVR TO AN HD TV

ilico TV new generation is suited to widescreen HD TVs with a 16:9 aspect ratio. The instructions listed below apply to HD TVs only. If you have a standard TV, or if your TV uses an alternative connection, please contact your retailer or call Technical Support at 1-877-380-2611.

RECOMMENDED CONFIGURATION

HDMI – The HDMI cable transmits high-definition digital video and audio to your TV, with a resolution of up to 1080i.

1. Plug in your Terminal using the recommended cable, as shown below.
If your TV does not support an HDMI connection, use an alternative connection.
2. Turn on the Terminal by pressing  on your remote control.
3. Turn on your TV and select the corresponding Audio/Video input (input 1/2/3 or component 1/2/3) to display content on-screen.
4. Complete the Quick-Start Wizard that automatically appears when your Terminal is turned on for the first time.
5. Program your remote control to your TV by following the instructions on page 10. This will, among other things, enable you to control the volume on your TV with the remote control for the Terminal.

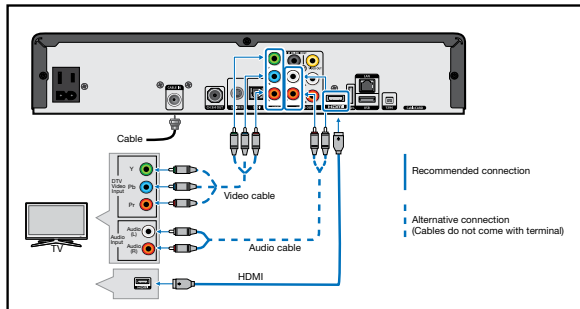

IMPORTANT:

1. If your screen is blank or starts blinking, please restart your Terminal by unplugging the power cord and plugging it back in.
2. If the problem persists, or if the "WIZ 502" error message pops up, please contact Technical Support at 1-877-380-2611.
3. For other types of connections, please see your retailer.
4. Should the self-installation fail, a fee may apply if a technician is required to come to your home.

For more information, visit us at videotron.com/terminal-support

YOUR REMOTE CONTROL

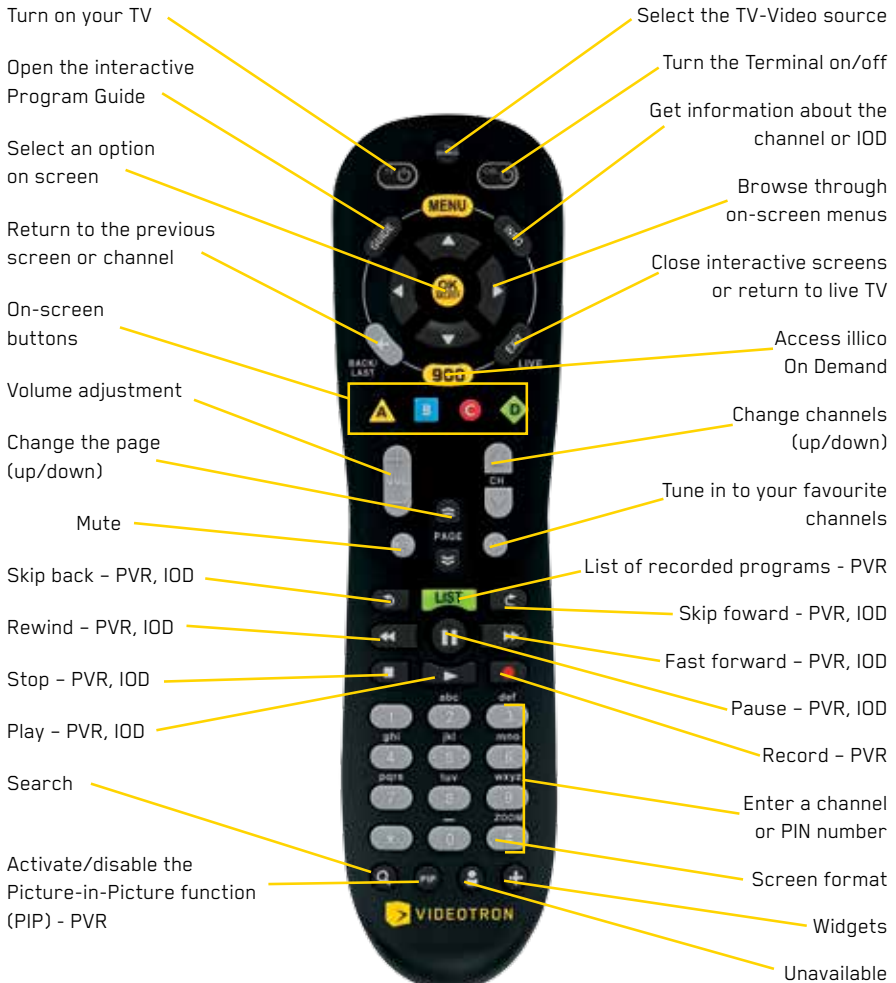

LEGEND:
PVR:HD PVR
IOD: illico On Demand

For more information, visit us at videotron.com/terminal-support

PROGRAMMING THE REMOTE CONTROL







To get the most out of your new Terminal, we recommend that you read the next few pages to ensure that you properly program your remote to your TV.

There are three ways to program your remote control:

- 1. Quick programming: for your TV only.**
- 2. Programming using automatic search: for your TV or audio system.**
- 3. Programming by code: for your TV or audio system.**

QUICK PROGRAMMING

If your TV brand is not among the 10 brands listed below, please use the Automatic Search Programming Method described on the next page.

1. Turn on your TV.
2. Press the  and  buttons simultaneously until the red light under the  button flashes twice, then release both buttons.
3. Press the  button once. The red light will turn on.
4. Point the remote at the TV. Refer to the table below and enter the number that corresponds to the brand of your TV set (i.e. 2 for LG). The red indicator light will flash twice and the TV will turn off.
5. Press  to confirm the code.
6. Turn your TV back on by pressing the  button. If the programming didn't work, repeat steps 2 to 5 or use the Automatic Search Programming method.
7. When your remote has been programmed, press  and select **Settings**.
8. Then select **Equipment Settings** and specify that the remote's volume adjustment keys control the TV's volume (see **Equipment settings** on p.12).

NUMBERS	HD TV BRAND
1	INSIGNIA
2	LG
3	MITSUBISHI
4	PANASONIC
5	PHILIPS/MAGNAVOX





NUMBERS	HD TV BRAND
6	SAMSUNG
7	SHARP
8	SONY
9	TOSHIBA
0	VIZIO

For more information, visit us at videotron.com/terminal-support

AUTOMATIC SEARCH PROGRAMMING



If the Quick Programming procedure did not work, follow the instructions below. This remote control programming method allows you to control your TV and your audio system.

NOTE: When you program the remote control to an audio system, it will only allow you to adjust the volume on the audio system, not the volume on the TV.

1. Turn on your TV and/or your sound system. First program your TV and then your sound system.
2. Press the  and  buttons simultaneously until the red light under the  button flashes twice, then release both buttons.
3. Press **9-9-1** on the remote control. The red light will flash twice.
4. Then press **1** to search for a TV code, or press **3** to search for a sound system code.
5. Point the remote control at the TV or the sound system. Repeatedly press and release the **CH+** button until the device turns itself off.
6. When the device is off, press the  button to confirm the programming. The red light will flash twice. If the programming did not work, repeat steps 2 to 5.
7. Repeat steps 2 to 5 to program your audio system.
8. When programming your remote control, press  and select "Settings."

RESETTING YOUR REMOTE CONTROL

If you would like to program your remote control to work with other devices, or if you are having problems getting it to work, you can reset it by following these steps:

1. Press the  and  buttons simultaneously until the red light under  blinks twice, then release both buttons.
2. Press **9-7-7** on your remote control. The red light will blink four times to confirm that the remote control has been reset.

NOTE: If neither of the two suggested programming methods worked, refer to the programming method by code in the complete version of the guide available on the Web.

EQUIPMENT SETTINGS

This section will help you configure your video and audio preferences so that you can get the most out of your HD TV and new Terminal.

Accessing your Terminal preferences:

1. Press **MENU** to go to the main menu.
2. Using **⏪** select **Settings** then **Equipment Settings**, then press **OK SELECT**.

You can choose:

- **When you would like your Terminal to switch to standby mode:** Configure your Terminal so that it turns off automatically when you want it to (date and time). When you would like your Terminal to turn on: Configure your Terminal so that it turns on automatically when you want it to (date and time).
- **The model of your remote control:** Select the model of your remote control to get the most out of its features.
- **The picture resolution:** It is important to choose a 1080i or 720p resolution, depending on the viewing mode of your HD TV. If you do not have an HD TV, you can choose a 480i or 480p resolution. HD channels are available after channel 600.
- **The volume control:** Determine whether you would like your remote to control the volume on your TV or Terminal. If your remote control has been programmed to your TV, please ensure that the volume control button is set to work with your TV or audio system.
- **The display:** Display the time on the Terminal when it is turned off.



HELP PORTAL

illico TV new generation now has a Help Portal that is accessible via the main menu. The Help Portal offers demos and a FAQ section concerning most of the available features.

How to access the Help Portal:

1. Press **MENU** to display the main menu
2. Using **⏪** select **Help** and press **OK SELECT**
3. Browse through the menu using the arrows **⏪**, select the subject you want and press **OK SELECT**
4. Under each heading you will find a FAQ section and demos concerning certain functions.

For more information, visit us at videotron.com/terminal-support

FREQUENTLY ASKED QUESTIONS

NOTICE: The first step in resolving problems related to the illico TV service is to reboot the Terminal. Rest assured—your Terminal settings, as well as the recordings on your Multi-Room HD PVR will remain intact. To reboot the Terminal, unplug the power supply cord, then plug it back in again a few seconds later. Wait a few minutes before turning the Terminal back on. If the problem persists, please contact Technical Support at 1-877-380-2611.

Where can I learn more about illico TV's Program Guide, menus and applications?

You can access our Help Portal from the main menu, as well as at support.videotron.com. This is where you'll find instructional videos and answers to the most frequently asked questions. To access the Help Portal via the illico TV main menu, press **MENU** on your remote control and select HELP.

Can I program my remote control to my TV?

To do so, follow the steps outlined on page 10.

I can't control the Terminal's volume with the remote control. Is this normal?

In order to provide you with the highest level of sound quality, the volume controls on the Terminal are disabled when the latter is connected with an HDMI cable. If this is the case, you will only be able to control the volume on your TV. You will have to program your remote control to your TV by following the instructions on page 10.

I programmed my remote control, and now the sound isn't working. What should I do?

You may have activated the Terminal's "Mute" function while programming the remote control by pressing OK/SELECT and MUTE. If this is the case, press the VOL+ button on your Terminal. This will disable the "Mute" function, and bring the sound back.

Why is the sound on my TV so low?

Your Terminal's Volume function controls the strength of the audio signal emitted by the Terminal. When the Terminal's volume is low, the signal it sends to the TV is equally low. To prevent this, we suggest that you program your remote control to your TV by following the instructions on page 10, and then program the Terminal so that you can only control the volume on your TV. To do this, please refer to the **Equipment Settings** section on page 12.

My Terminal is not working, or my TV screen is black, blue, blurry or snowy. What should I do?

Make sure the Terminal is turned on and that you followed the steps for activating (on page 4) and connecting (on page 8) the Terminal. Because your TV has multiple inputs, it's important to let your TV know the one you're using. Set your TV to the right input using the remote control it came with, i.e. by setting it to either Input 1, 2 or 3; Component 1, 2 or 3; or HDMI 1, 2 or 3.

For more information, visit us at videotron.com/terminal-support

The sound cuts or the picture breaks up when I watch TV. What should I do?

Reboot the Terminal by unplugging the power supply cord and plugging it back in. If the problem persists, restart the Terminal as indicated above, or contact Technical Support at 1-877-380-2611.

When I plug in my Terminal with an HDMI cable, the picture breaks or an error message appears onscreen. What should I do?

Once you've made sure that the HDMI cable is properly plugged into the Terminal, reboot the Terminal by unplugging the power supply cord and plugging it back in. If the problem persists, it may be that your TV is not compatible with the Terminal's HDMI port. Instead, proceed with the alternative connection by using a component cable. Seeing as the Terminal does not come with a component cable, please contact your retailer or call Technical Support at 1-877-380-2611.

Is it normal that broadcasts on certain channels don't fill the screen?

Yes. The only channels that broadcast full-screen are HD channels (channels after channel 600 and up). Channels where the picture does not fill the screen are standard-definition channels. However, some shows airing on HD channels are broadcast in standard definition.

How can I switch to full screen mode when I'm watching a channel that's broadcast in standard definition?

The # button on your remote control allows you to stretch the picture or to zoom in and get rid of the black bars that border the left and right of the screen when you're watching a channel in standard definition. Press # until you obtain the desired zoom mode: Normal, Large or Zoom.

After activating my Terminal, is it normal that I can access channels that are not included in my TV package?

Yes. Once you have activated your Terminal, you'll be able to access the channels included in your TV package on the business day following the activation date. As a result, you'll have free, temporary access to several channels that aren't necessarily part of your TV package.

CUSTOMER SERVICE

For further information, we invite you to visit the illico TV Help Portal, to check out instructional videos at videotron.com/Terminal-support or to contact Customer Service. You can reach a representative Monday–Friday from 7:30 a.m. to 10 p.m., Saturdays from 8 a.m. to 8 p.m. and Sundays from 9 a.m. to 8 p.m.

Montréal 514-281-1711

Québec City 418-847-4410

Saguenay 418-545-1114

Outaouais 819-771-7715

Elsewhere in Québec 1-888-433-6876

TECHNICAL SUPPORT

For problems of a technical nature, we invite you to contact Technical Support. You can reach a representative 24 hours a day, 7 days a week.

Montréal 514-841-2611

Québec City 418-842-2611

Saguenay 418-543-4611

Outaouais 819-771-2611

Elsewhere in Québec 1-877-380-2611

**THE COMPLETE USER GUIDE IS AVAILABLE AT
VIDEOTRON.COM/TERMINAL-SUPPORT**

SECURITY

For security purposes, please read the following before connecting your Terminal.

POSITIONING AND VENTILATION

The Terminal has openings for ventilation that protect it from overheating.

- Avoid obstructing these openings and do not place other equipment, including televisions, lamps, books or any other objects, on the Terminal. Do not place it in an enclosure such as a bookcase or equipment rack, unless suitable ventilation is provided.
- Do not place the Terminal on a bed, sofa, rug or similar surface, or close to a radiator or source of heat.
- Lay the Terminal on a stable surface that's able to support its size and weight.

ACCESSORIES AND CLEANING

Only use Videotron-recommended accessories. Do not open the cover of the Terminal. Unplug the Terminal and clean it with a damp cloth. Do not use a liquid or aerosol cleaner, or a magnetic/static cleaning device.

OBJECT AND LIQUID ENTRY

Do not expose the unit to moisture, or spill liquid on or near it. Do not place the unit on a wet surface. Never push objects of any kind into the unit's openings, as they may touch dangerous voltage points or cause short-circuits that could result in a fire or electric shock.

POWER SOURCES

A label on the unit indicates the correct power source for this equipment. Operate the unit only from an electrical outlet that has the voltage and frequency indicated on the label. Do not overload electrical outlets or extension cords, as this could result in a fire or electric shock.

POWER CORD PROTECTION

To avoid damaging them, arrange all power cords so that they are not walked on and make sure no objects are placed on or against them. Pay particular attention to cords that are connected to plugs, electrical outlets or accessories, and to the places where the cords exit the unit.

For more information, visit us at videotron.com/terminal-support

CAUTION! To prevent electric shock, match wide blade of plug to wide slot, then insert fully. If you are unable to fully insert the plug into the outlet, contact an electrician to replace your obsolete outlet.

GROUNDING

The Terminal has a two-prong plug. Properly ground the unit by inserting the plug into a grounded electrical, two-socket outlet. If the plug is polarized, it has one wide prong and one narrow prong. This plug fits only one way.

SERVICING

This unit is covered by a three-year warranty. Opening the case will void your warranty. Refer all servicing to a qualified Videotron technician. Contact your cable service provider for instructions. Service should be referred to a Videotron technician when any of the following occurs:

- There is damage to the power cord or plug.
- Liquid enters the unit, or there is exposure to rain or water.
- A heavy object falls on the unit, or you drop the unit or damage the casing.
- The unit malfunctions (the instructions in this guide describe the proper operation).
- The unit shows a distinct change in performance.

EXTENDED WARRANTY

For greater peace of mind, Videotron offers you the possibility of extending the warranty for an additional two years. Customers who want this extended warranty must apply for it within 30 days of the service activation date. The unit purchased will then be covered for a total of five years following the activation date.

